

| | | | | | |
|----------|------------|-----|-------|----------|-----|
| PART NO. | A41297-002 | REV | ECO | DATE | APP |
| | | B | 99344 | 03-11-13 | TLM |

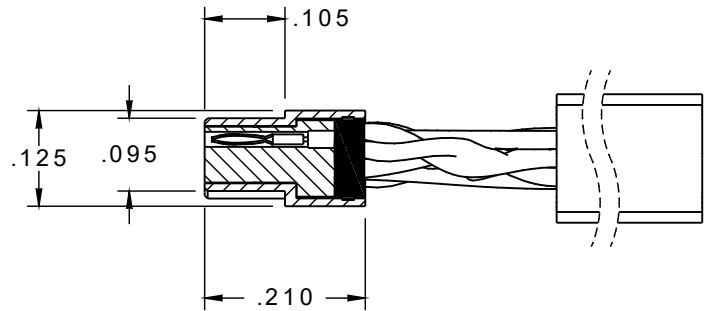

SECTION A-A
VIEW LESS HARDWARE
AND SHRINK TUBES

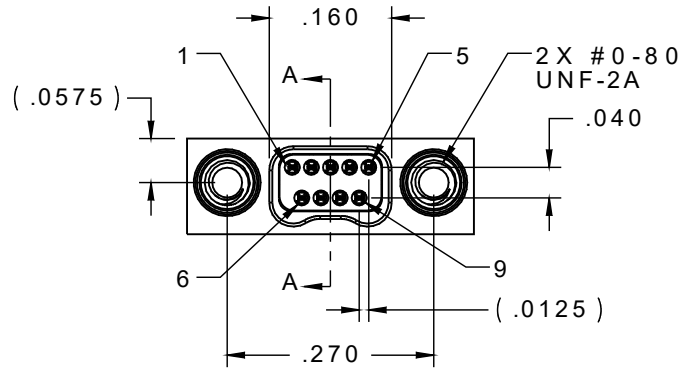
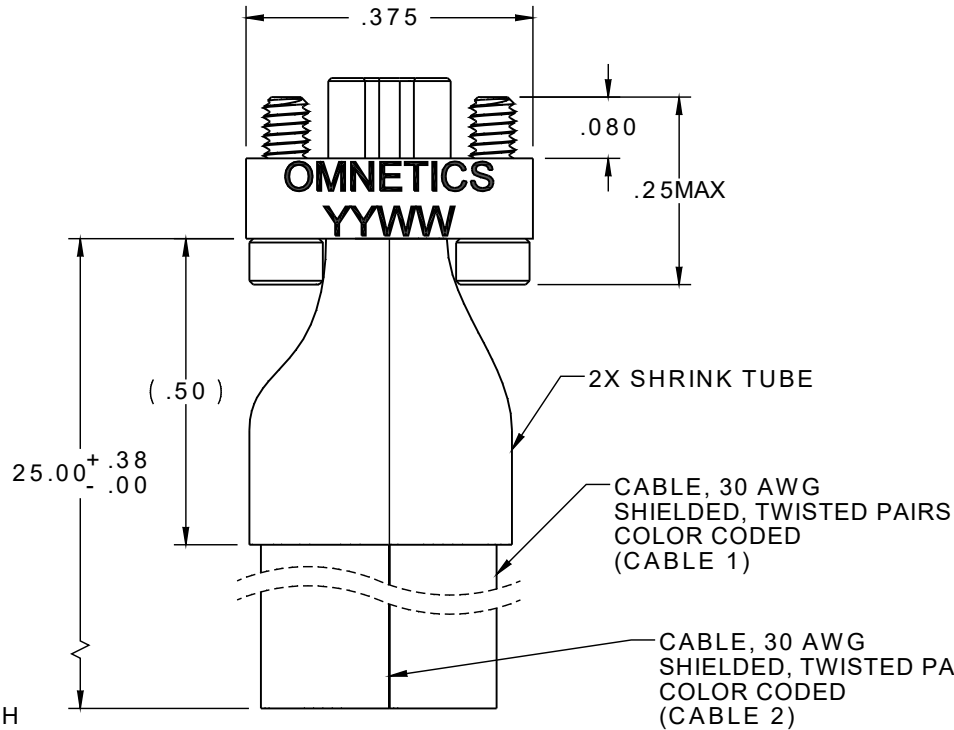

| PIN # | COLOR | CABLE # | NOTES |
|-------|--------|---------|-------|
| 1 | BLACK | 2 | |
| 2 | BROWN | 2 | |
| 3 | RED | 1 | - |
| 4 | BLACK | 1 | |
| 5 | BROWN | 1 | |
| 6 | RED | 2 | |
| 7 | ORANGE | 2 | |
| 8 | YELLOW | 2 | - |
| 9 | BLUE | 2 | - |



ACTUAL SIZE
EXCLUDING CABLE LENGTH

NOTE:
TRIM SHIELD FLUSH
WITH CABLE JACKET

| | |
|------------------|------------------------|
| MNP/SLD/DM | THIRD ANGLE |
| | -TOLERANCES- |
| | UNLESS OTHERWISE NOTED |
| | DIMENSIONS IN INCHES |
| 2 PL DEC ± .01 | |
| 3 PL DEC ± .005 | |
| 4 PL DEC ± .0005 | |
| ANGLES ± 1° | |

| | |
|--|---------------|
| THIS DRAWING CONTAINS CONFIDENTIAL AND PROPRIETARY INFORMATION WHICH IS THE PROPERTY OF OMNETICS CONNECTOR CORP. THIS DOCUMENT MAY NOT, IN WHOLE OR IN PART, BE DUPLICATED, OR DISCLOSED FOR ANY PURPOSE, WITHOUT WRITTEN PERMISSION FROM OMNETICS CONNECTOR CORP. | |
| DFTM. TLM | DATE 06-22-10 |
| CHK'D. | DATE |
| APP'D. | DATE |
| TITLE: (9) PIN MALE Bi-Lobe® CONNECTOR | |

OMNETICS
CONNECTOR CORPORATION
7260 COMMERCE CIRCLE EAST
MINNEAPOLIS, MN 55432
WWW.OMNETICS.COM

| | |
|--------------------|-------|
| CAGE CODE 61873 | |
| DWG NO. A41297-002 | |
| SHEET 1 OF 2 | REV B |
| SCALE: 4:1 | |